

# ENGINE DRIVEN WELDER CS 230 YSX CC/CV

The images are for reference

## WELDING PROCESS

Shielded Metal Arc welding SMAW (STICK)

Gas Tungsten Arc Welding GTAW (TIG)

Gas Metal Arc Welding GMAW (MIG)

Flux Cored Arc Welding FCAW (FLUX CORED)



## FEATURES

- Arc welding source in D.C. welding
- High frequency control of welding current and voltage
- Engine cowling side, can be completely opened, which facilitates all maintenance operations
- The recessed control panel is lockable and houses the sockets and machine
- A.C. generator, single-phase and three-phase
- Aux power also available while welding
- Power optimiser (engine power optimization system)
- VRD - Voltage reduction device
- Large fuel tank (23 l)
- Meets EC directives for noise and safety

## DEFINITIONS

**SMAW:** Coated electrode welding is an arc welding with protected metal.

**GMAW:** welding is an arc process with metal under gas protection.

**FCAW (FLUX CORED):** The process with cored wires is very similar to MIG / MAG welding. Continuous wire is not full but consists in a metal strip that wraps a powders core (flow).

**GTAW:** is a welding process that uses a tungsten electrode that cannot melt.



air cooled



diesel



electric starter



Chopper System

## ENGINE 3000 RPM

### 4 STROKE, DIRECT INJECTION, NATURAL ASPIRATED

Model	YANMAR L 100 V
* Stand-By net power	6.3 kWm (8.5 hp)
* PRP net power	5.7 kWm (7.7 hp)
* COP net power	/
Cylinders / Displacement	1 / 435 cm <sup>3</sup> (0.27 lt.)
Bore / Stroke	86 / 75 (mm)
Compression ratio	20 : 1
BMEP (Brake Mean Effective Pressure : LTP - PRP)	/
Speed governor type	Mechanical
<b>FUEL CONSUMPTION</b>	
110 % (Stand-by power)	1.9 lt./h
100 % to PRP	1.7 lt./h
75 % to PRP	1.2 lt./h
50 % to PRP	0.8 lt./h
<b>COOLING SYSTEM</b>	
Total system cap. - only engine	/
Fan air flow	/
<b>LUBRICATION SYSTEM</b>	
Total oil system capacity	/
Oil capacity in sump	1.6 lt.
Oil consumption at full load	/

\* Output powers according to ISO 3046-1

### EXHAUST SYSTEM

Maximum exhaust gas flow	/
Max. exhaust gas temp.	/
Maximum back pressure	4.3 kPa (0.043 bar 440 mmH <sub>2</sub> O)
External diameter exhaust pipe	/

### ELECTRICAL SYSTEM

Starter motor power	0.8 kW
Battery charging alternator cap.	15 A
Cold start	- 10°C
With cold start aid	/

### AIR FILTER

Combustion air flow	/
---------------------	---

### HEAT REJECTED AT FULL LOAD

To exhaust system	/
To water and oil	/
Radiated to room	/
To charge cooler	/

# WELDING AND GENERATION

## C.C. WELDING (CONSTANT CURRENT)

SMAW (STICK)/ GTAW (TIG) CC MODE	
Current range	20 ÷ 210 A
Type of regulation	continue
Duty cycle	210A 60%   180A 100%
Open circuit voltage	68 V
Arc Force Regulation	Si

## C.V. WELDING (CONSTANT VOLTAGE)

GMAW (MIG)/ FCAW (FLUX CORED) CV MODE	
Welding voltage	16V ÷ 40V
Type of regulation	continuous
Duty cycle	500A - 60% / 450A - 100%

## GENERAL SPECIFICATIONS

Fuel tank capacity	23 l
Starter Battery	12 Vdc -37Ah / 330A CCA(EN)
Fuel consumption (welding 60%)	1 l/h
Running time (welding 60%)	20 h
IP protection degree	IP 23

Guaranteed acoustic power LwA (pressure LpA)	91.2 dB(A) (66.2 dB(A) @ 7 m)
Measured acoustic power LwA (pressure LpA)	93 dB(A) (68 dB(A) @ 7 m)
Max. ambient temperature	/

## A.C. GENERATION

### ASYNCRONOUS THREE-PHASE, SELF-REGULATED, SELF-EXCITED, BRUSHLESS

Insulation class	H
------------------	---

## GENERAZIONE AUSILIARIA

OUTPUT 1	
Type of source	Three-phase
Frequency	50 Hz
Apparent Power (Active Power)	6kVA (4.8kW)
Cos φ	0.8
Voltage	400V
Current	8.7A

OUTPUT 2	
Type of source	Single-phase
Frequency	50 Hz
Apparent Power (Active Power)	5kVA (4kW)
Cos φ	0.8
Voltage	230V SCHUKO
Current	21.7A

OUTPUT 3	
Type of source	Single-phase
Frequency	50 Hz
Apparent Power (Active Power)	2.5kVA (4kW)
Cos φ	1
Voltage	110V
Current	22.7A

OUTPUT 4	
Type of source	/
Frequency	/
Apparent Power (Active Power)	/
Cos φ	/
Voltage	/
Current	/

The use of the Auxiliary Generation is recommended for tools related to welding (wheels, electric hammers, lights, etc ...)

## SIMULTANEOUS LOAD CHARACTERISTIC

WELDING CURRENT	≥ 150 A	125 A	100 A	75 A	50 A	0 A
POW. IN THREE PHASE 400V	0 kW	1.2 kW	2.2 kW	3 kW	3.5 kW	4.8 kW
POW. IN SINGLE PHASE 230V	0 kW	1.2 kW	2.2 kW	2.7 kW	3 kW	4 kW
POW. IN SINGLE PHASE 115V	0 kW	1 kW	1.3 kW	1.7 kW	2 kW	2.5 kW



# CONTROL PANEL

## ENGINE

- Engine start and stop key
- Thermal circuit breaker for motor protection: 1x5A
- Low oil pressure warning light with engine stop
- Low fuel warning light with stop
- Battery charge warning light
- Multifunction digital instrument: AC voltmeter - Frequency meter - Total hour meter Partial hour meter (resettable) - Battery voltmeter
- Emergency stop button

## WELDING

- WAC control panel:
  - CC-CV welding mode switch
  - Welding current / voltage adjustment knob
  - Welding arc adjustment knob
  - Remote control connection connector. Automatic "local / remote" switching on insertion of the connector. 10 POLES
  - VRD / VRD LED
- Welding outlet sockets: 1 x Welding (+) 400A  
1 x Welding (-) 400A



## GENERATION (VERS. 400V/230V)

- Differential switch (400V / 230V)
- Thermal breakers for socket protection:
  - 1x 16A for 230V 16A 2P + E CEE socket
  - 1x 16A for 230V 16A 2P + T SCHUKO socket
- Output sockets: 1x 400V 16A 3P + N + T CEE IP44  
1x 230V 16A 2P + T CEE IP44  
1x 230V 16A 2P + T SCHUKO IP54
- Earth terminal (PE)

## GENERATION (VERS. 230V/110V)

- Differential switch (230V)
- Magnetothermic switch for 230V-16A socket
- Magnetothermic switch for 110V-32A CEE sockets and 110V-16A CEE socket (one for the 2 sockets)
- Output sockets: 1x 110V 32A 2P + T CEE IP44  
1x 110V 16A 2P + T CEE IP44  
1x 230V 16A 2P + T CEE IP44
- Earth terminal (PE)

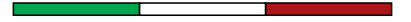

# WEIGHT - DIMENSIONS ACCESSORIES

CS 230 YSX CC / CV



**DRY WEIGHT:**  
• 230 Kg

The welding machine pictured may include optional accessories.



**DIMENSION PICTURE**

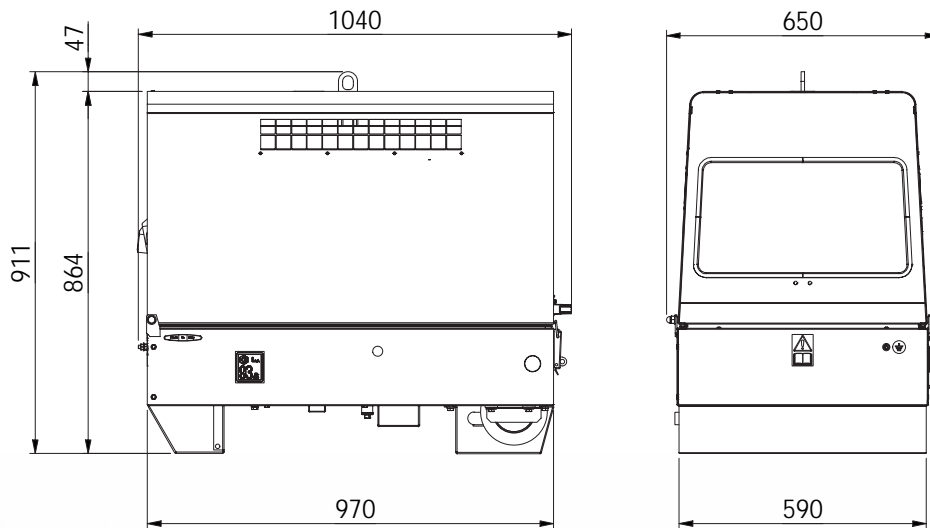

### ⊕ OPTIONS ON REQUEST

- Remote control RC2
- Remote control extension cord (30m)
- WF4 wire-feeder
- Welding cables: K190 (10+8 m, 35 mm<sup>2</sup>)  
K200 (20+15 m, 35 mm<sup>2</sup>)
- Welding kit (mask gloves, etc.)
- Earthing kit
- Trolley CTM2
- Road tow running gear CTV4
- Exhaust extension

### ⊗ VERSION ON REQUEST

- Version 400V/110V

### ⊖ OPTIONS FACTORY INSTALLED

- Auto-Idle
- Disabling VRD function

## GENERAL INFORMATION

### COMPLIANCE GENERATING SETS WITH EC DIRECTIVES AND STANDARDS

- 2006/42 / EC (Machines Directive)
- 2014/35 / EU (Low Voltage Directive)
- 2014/30 / EU (EMC Directive)
- 2000/14 / EC (Directive Acoustic Emission for machines for use outdoors)
- ISO 8528 (Reciprocating internal combustion engine driven alternating current generating sets)



ISO 9001:2015 - Cert. 0192

### WARRANTY

All devices are covered by the manufacturer's warranty.

The company reserves the right to change this specification without notice. For further information please contact the sales department.

© MOSA - Viale Europa, 59 - 20090 Cusago (Milano) - Italy - phone +39-0290352.1 - fax + 39-0290390466 E-mail: info@mosa.it Web site: www.mosa.it

